

QUADRO 2137

Empower your production with advanced technology, a robust mechanical structure, and smart solutions.



High Performance Maximum Efficiency

Italian Control Interface

With its user-friendly, advanced control interface, full compatibility, and highly secure communication protocol, the machine operates smoothly at high speeds.



Automatic 16-Tool Changer

In automatic mode, the machine performs all tool-changing operations automatically. In addition, the system automatically measures the tool length independently of the user, saves it to memory, and continues operation using the recorded tool length. If needed, the tool-changing process can also be performed manually under operator control.

Vacuum-Controlled Table With 4 Zones and 8 Outputs

The vacuum worktable is made of compact laminate material. In the standard series, the table consists of 4 vacuum zones. It provides flexible use with powerful vacuuming and zone control.

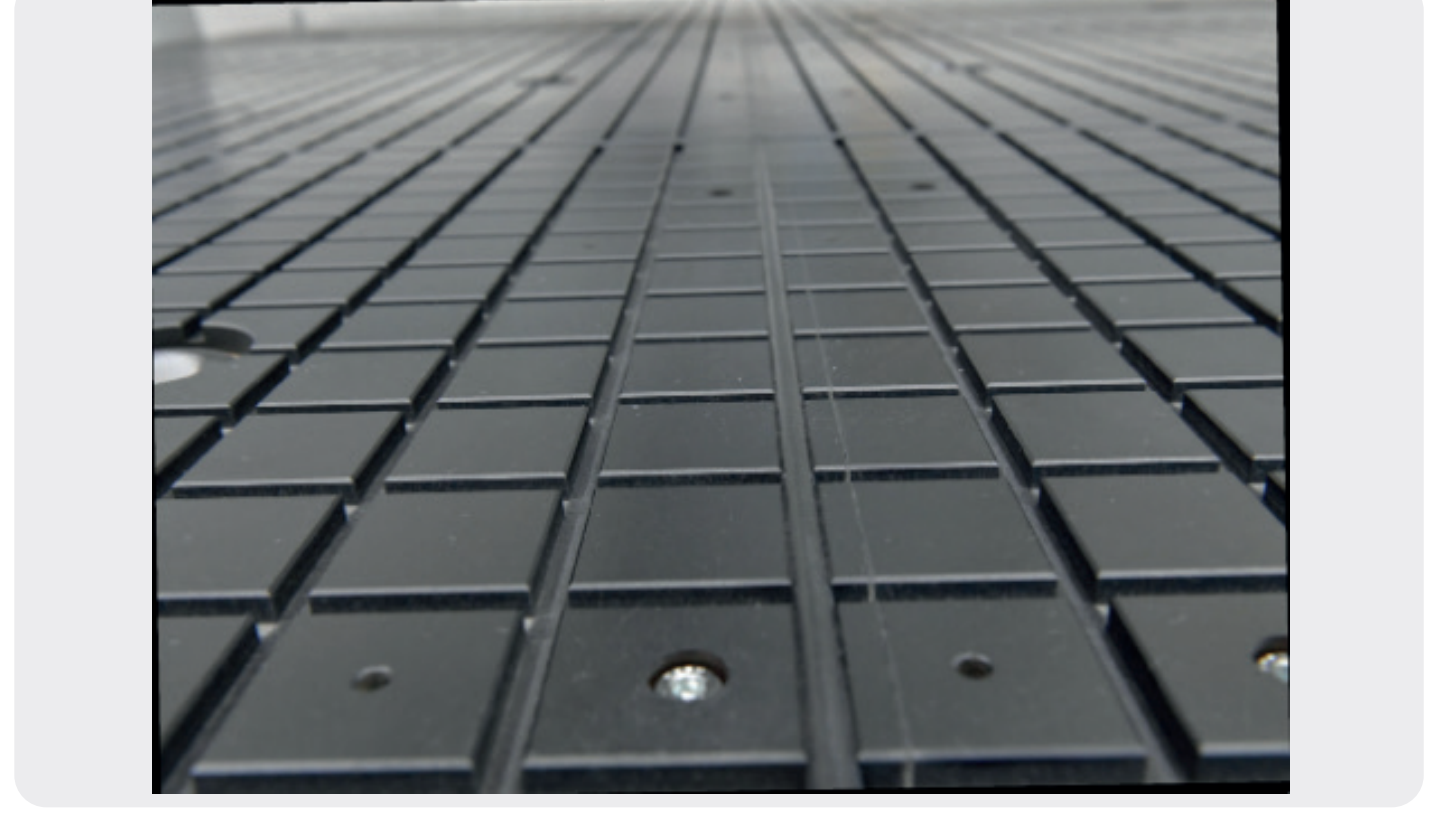

Powerful Motor Structure with the Ability to Process Various Materials

Our products use high-performance Italian spindle motors with HSK F63 tool holders. It can easily process wood, plastic, plexiglass, aluminum composite panels, aluminum, and soft metals.

Wired Handwheel

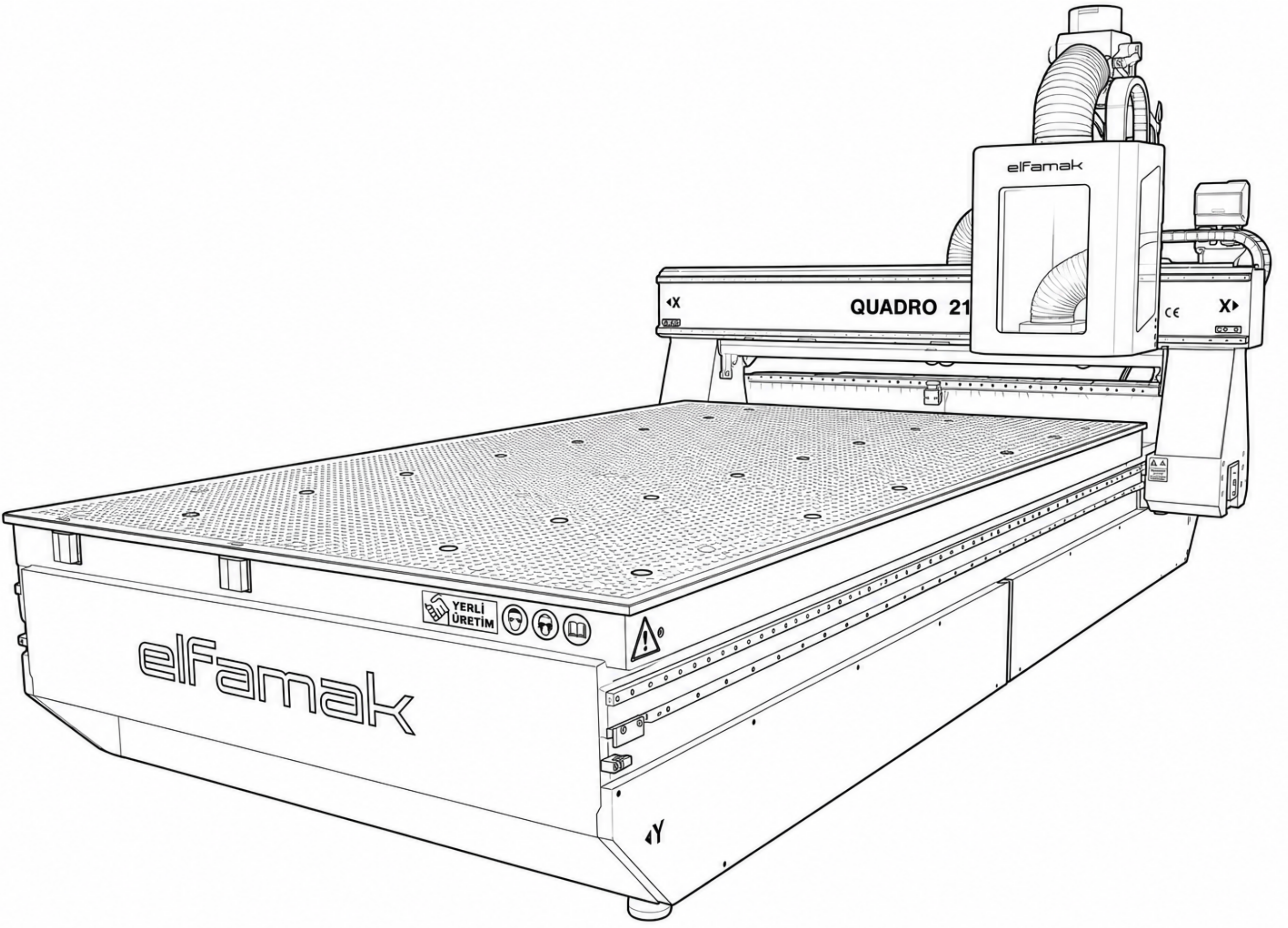

Click for VIDEO



Click for CATALOG